

Detection of Sulfur Compounds in Natural Gas According to ASTM D5504 with an Agilent Dual Plasma Sulfur Chemiluminescence Detector

Application Note

Author

Rebecca Veeneman

Abstract

Sulfur compounds in natural gas samples are detected using an Agilent 7890B gas chromatograph configured with an Agilent 8355 dual plasma sulfur chemiluminescence detector (SCD). The 8355 SCD provides linear, equimolar responses from 0.15 to 10 ppm.



Agilent Technologies

Introduction

The petrochemical industry's profits are generated by keeping their cleanup, refining, blending, and characterization processes running as efficiently as possible. Most of these processes can be negatively impacted when dealing with sulfur compounds. Being able to measure sulfur compounds reliably and routinely is an absolute must so that they can optimize their processes at any given time.

When dealing with natural and petroleum gases, sulfur compounds can be present in two forms. First, naturally occurring contaminants during harvest. Secondly, sulfur-based odorant additives for traceability and safety purposes.

A gas chromatograph (GC) equipped with a sulfur chemiluminescence detector (SCD) provides a rapid and efficient means of identifying and quantifying the sulfur compounds present at the various refinement stages. Various detectors exist for the detection of sulfur compounds, but the SCD provides the most specific and sensitive method for analysis.

ASTM D5504 provides guidelines for the determination of volatile sulfur-containing compounds in high methane content gaseous fuels. It has been successfully applied to other fuel-type gases containing sulfur compounds that are often regulated and monitored by regulatory commissions as well as the production/distribution facilities.

The Agilent 8355 dual plasma SCD provides linear, equimolar responses to sulfur-containing compounds with minimal hydrocarbon interference. This improves ease-of-use for data collection and analysis since it eliminates the need to linearize the data, and determine separate response factors for each compound of interest. The 8355 SCD also provides a stable response that is not quenched by hydrocarbons. This Application Note addresses the linearity, stability, and practical detection limits of the 8355 SCD installed on an Agilent 7890B GC equipped with a DB-Sulfur SCD column of 4.3 μm film thickness.

Experimental

An Agilent 7890B GC was configured with a deactivated two-valve system, and an Agilent 8355 SCD. Sample introduction was achieved through a 10-port gas sample valve interfaced to a deactivated purged ultimate union through deactivated tubing. Standards

were diluted using an online dilutor that interfaced through a 6-port gas sample valve. Figure 1 shows the valve configuration used. Table 1 presents the compound information. The sulfur standards were blended with helium for this application, but the system is capable of introducing matrix.

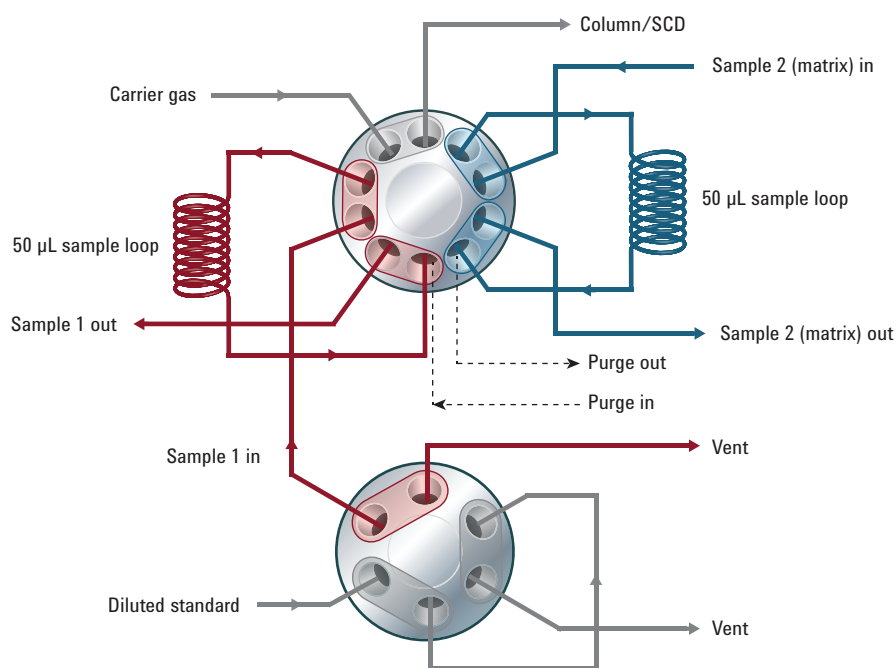

Figure 1. A diagram of the 2-valve system used for dilution and sample introduction is shown.

Table 1. Sulfur standards components.

Compound	Formula
Hydrogen sulfide	H_2S
Carbonyl sulfide	COS
Methyl mercaptan	CH_3SH
Ethyl mercaptan	$\text{CH}_3\text{CH}_2\text{SH}$
Dimethyl sulfide	CH_3SCH_3
Carbon disulfide	CS_2
2-Propanethiol	$\text{CH}_3\text{SCH}_2\text{H}_5$
<i>tert</i> -Butyl mercaptan	$(\text{CH}_3)_3\text{CSH}$
1-propanethiol	$\text{CH}_3(\text{CH}_2)_2\text{SH}$
Thiophene	$\text{C}_4\text{H}_4\text{S}$
<i>n</i> -Butyl mercaptan	$\text{CH}_3(\text{CH}_2)_3\text{SH}$
Diethyl sulfide	$\text{CH}_3\text{CH}_2\text{SCH}_2\text{CH}_3$
Methyl ethyl sulfide	$\text{CH}_3\text{SCH}_2\text{CH}_3$
2-Methyl-1-propanethiol	$(\text{CH}_3)_2\text{CHCH}_2\text{SH}$
1-Methyl-1-propanethiol	$\text{CH}_3\text{CH}_2\text{CHSHCH}_3$

Table 2 shows instrument conditions.

Results and Discussion

Repeatability and linearity

Linearity was evaluated for the 15 analytes ranging from approximately 0.1 to 10 ppm. Table 3 gives the repeatability (calculated as the peak area RSD of 10 injections) for each analyte at each concentration, along with R^2 values. The two lowest concentrations gave the highest average RSD, at 6.3 %. Concentrations in the 5.5 ppm and 1.5 ppm yielded better average RSDs of 2.0 % and 2.7 %, respectively. Analytes such as 1-propanethiol yielded higher area RSDs, in general due to the decreased resolution between it and thiophene. Later-eluting analytes also showed higher RSDs due to low responses. The highest concentration at 9.9 ppm yielded an average RSD of 5.0 %. The linearity was generally good, with an average R^2 value of 0.996.

Table 2. Instrument conditions.

Parameter	Value
Agilent 7890B GC	
Sample introduction	10-port GSV
Temperature	150 °C
Oven	30 °C (1.5 minutes) 15 °C to 250 °C (3 minutes)
Column	Agilent DB-Sulfur SCD, 70 m × 530 μm, 4.3 μm (G3903-63003)
Constant flow	6 mL/min
Agilent 8355 SCD	
Base temperature	250 °C
Burner temperature	800 °C
Upper H ₂ flow	38 mL/min
Lower H ₂ flow	8 mL/min
Oxidizer flow	60 mL/min
Ozone generator	40 mL/min
Nominal burner pressure	366 torr
Nominal reaction cell vacuum	3–5 torr

Table 3. Repeatability and linearity for the 15 sulfur compounds analyzed.

Analyte	9.9 ppm	5.5 ppm	1.5 ppm	0.793 ppm	0.149 ppm	R^2
Hydrogen sulfide	4.4 %	1.0 %	0.7 %	5.8 %	6.7 %	0.999
Carbonyl sulfide	2.3 %	0.4 %	2.4 %	6.0 %	6.5 %	0.9996
Methyl mercaptan	4.6 %	0.9 %	1.7 %	6.4 %	10 %	0.9979
Ethyl mercaptan	5.3 %	1.0 %	1.6 %	5.4 %	ND	0.9982
Dimethyl sulfide	4.0 %	0.6 %	1.1 %	4.0 %	9.0 %	0.9997
Carbon disulfide	4.2 %	0.8 %	0.6 %	4.2 %	4.3 %	0.9999
2-propanethiol	5.8 %	4.3 %	4.9 %	9.4 %	ND	0.9753
<i>tert</i> -Butyl mercaptan	5.7 %	1.3 %	3.3 %	6.6 %	ND	0.9976
1-Propanethiol	9.0 %	5.5 %	4.7 %	ND	ND	0.9934
Thiophene	4.6 %	1.2 %	1.8 %	4.8 %	3.5 %	0.9999
<i>n</i> -Butyl mercaptan	4.8 %	0.9 %	1.4 %	3.5 %	4.8 %	0.9998
Diethyl sulfide	6.1 %	5.5 %	ND	ND	ND	0.9833
Methyl ethyl sulfide	5.4 %	1.4 %	2.3 %	8.9 %	ND	0.9986
2-Methyl-1-propanethiol	3.9 %	2.6 %	7.6 %	7.8 %	ND	0.9979
1-Methyl-1-propanethiol	5.3 %	2.4 %	3.5 %	9.4 %	ND	0.9990

Linearity was very good for all the compounds evaluated. Figure 2 shows calibration plots for four analytes of interest. The four analytes chosen are representative of the 15 compounds evaluated, and demonstrate the

linearity observed across the various functional groups and retention times. Five replicate injections were plotted at each concentration level, demonstrating superior confidence of repeatability across the concentration range.

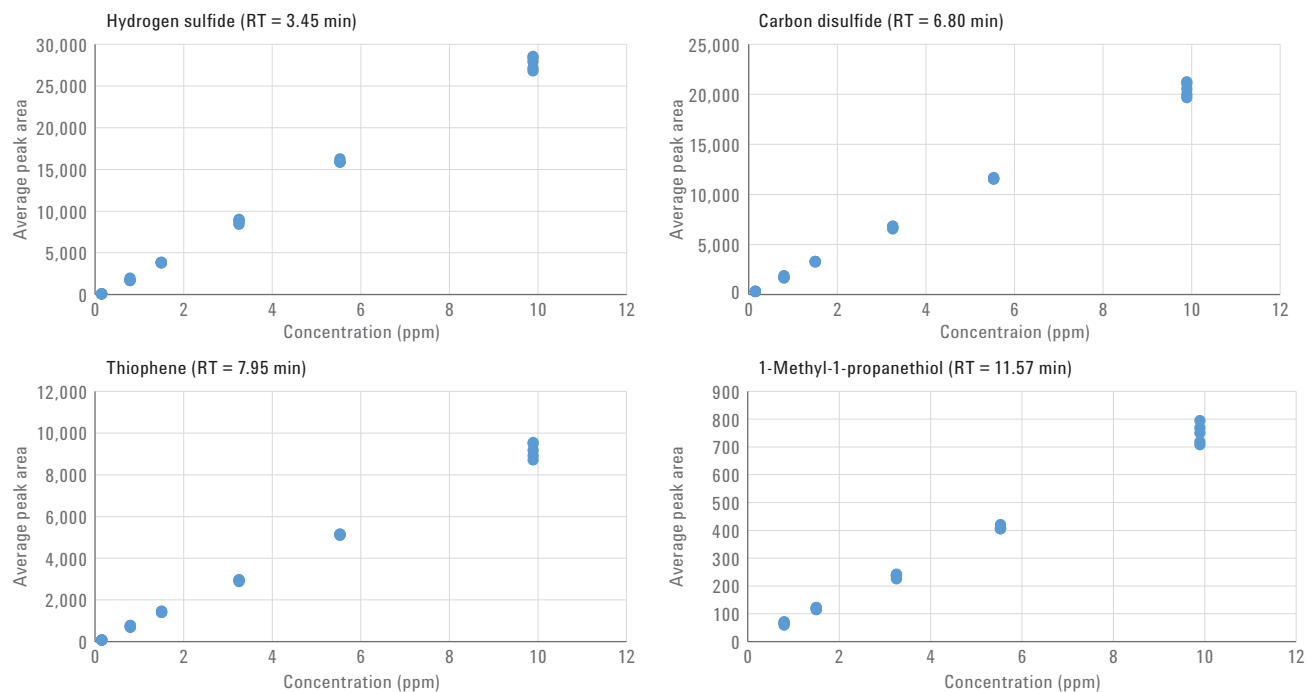

Figure 2. Calibration plots for four sulfur compounds of interest. These plots are representative of the 15 analytes examined.

Limit of detection (LOD) evaluation

Using the standard at approximately 1.5 ppm, a practical LOD was calculated for each compound in the mix. Table 4 shows that the detection limits range from 0.076 pg/sec for hydrogen sulfide to 5.548 pg/sec for 1-propanethiol. Diethyl sulfide was not detected at the 1.5 ppm concentration because of its coelution with methyl ethyl sulfide. Analytes with less resolution (for example, 1-propanethiol and diethyl sulfide) show higher LODs. As with repeatability, the later-eluting compounds also show higher LODs because of their low responses. Figure 3A shows a representative chromatogram from the 1.5 ppm standard used in this determination of detection limits. Figure 3B shows the chromatogram obtained from the 150 ppb concentration for comparison.

Table 4. A practical LOD was determined for the 15 component mix from the 1.5 ppm standard.

Peak	Analyte	LOD (pg/sec)
1	Hydrogen sulfide	0.076
2	Carbonyl sulfide	0.18
3	Methyl mercaptan	0.45
4	Ethyl mercaptan	1.0
5	Dimethyl sulfide	0.19
6	Carbon disulfide	0.090
7	2-Propanethiol	1.4
8	<i>tert</i> -Butyl mercaptan	1.6
9	1-Propanethiol	6.2
10	Thiophene	0.21
11	<i>n</i> -butyl mercaptan	0.22
12	Diethyl sulfide	ND
13	Methyl ethyl sulfide	0.39
14	2-Methyl-1-propanethiol	3.2
15	1-Methyl-1-propanethiol	2.4

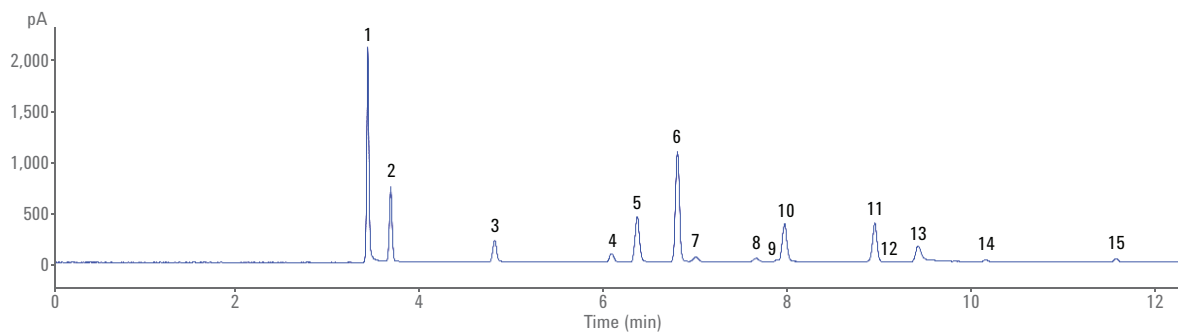

Figure 3A. The sulfur standard at 1.5 ppm. This concentration was used calculate LODs for this mix.

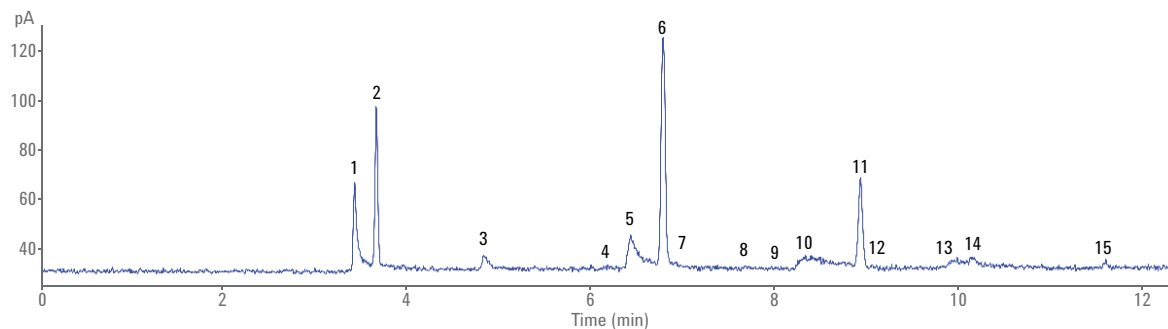

Figure 3B. The sulfur standard at 150 ppb. While some analytes are not detected, hydrogen sulfide (1), carbonyl sulfide (2), carbon disulfide (6), and *n*-butyl mercaptan (11) show excellent peak shape.

Conclusions

The petrochemical industry relies heavily on measuring sulfur compounds throughout their various processes. Sulfur compounds naturally exist, or are added to natural gas and liquid petroleum gases. The quantitation of such gases is necessary for quality control and safety purposes.

The Agilent 8355 dual plasma sulfur chemiluminescence detector provides a linear response for a wide range of sulfur-containing compounds. Area repeatability is very good for most the analytes examined down to 150 ppb. Linearity was very good for all analytes in the standard, with a practical LOD of 0.5 pg/sec or better for over half of the compounds. While this is flow rate and analyte dependent, it is roughly equivalent to 500 ppb, which is more than adequate for many ASTM applications.

Reference

1. ASTM D5504-98: Standard test method for determination of sulfur compounds in natural gas and gaseous fuels by gas chromatography and chemiluminescence.

www.agilent.com/chem

This information is subject to change without notice.

© Agilent Technologies, Inc., 2016
Published in the USA, April 4, 2016
5991-6819EN



Agilent Technologies